

with the transmutation values. For the Zn^{67} - Zn^{66} differences, the weighted mean of our value and the transmutation value is 1.00135 ± 16 AMU. If this be the correct value, it indicates that the Minnesota value for Zn^{66} is too large by ~ 0.4 mMU. Such a change would remove the Zn^{66} - Cu^{65} discrepancy and, in the light of the smaller Zn^{64} value would

provide a concordant value for the Zn^{66} - Zn^{64} difference.

We appreciate the assistance of our colleague, J. G. V. Taylor, in the calculation of the transmutation mass differences. The work reported in this paper has been supported by the Office of Scientific Research, Air Research and Development Command, U.S. Air Force, the National Research Council of Canada, the Ontario Research Foundation and the Shell Oil Company of Canada.

Preliminary Report on a large Mass Spectrograph newly constructed at Osaka University

By K. OGATA and H. MATSUDA

Department of Physics, Faculty of Science, Osaka University
(Z. Naturforschg. **10a**, 843-850 [1955]; eingegangen am 28. Juli 1955)

To J. Mattauch for his 60th birthday

A new large mass spectrograph of double focusing type was constructed at Osaka University. The apparatus has a uniform magnetic field of $\pi/3$ sector type and $\sqrt{2}\pi/3$ cylindrical electric field. The radius of central ion beam in magnetic field is 1200 mm and that in electric field 1093 mm.

From the preliminary experiment, the dispersion coefficient was estimated to be about 9 cm for 1% mass difference and the maximum resolving power about 500,000. In the preliminary determination of N_2^{14} - $C^{12}O^{16}$ doublet mass difference, a value of 112.441 (10^{-4} amu) was obtained with the present condition.

In the past we have constructed a mass spectrograph of Bainbridge-Jordan type at Osaka University. With the mass spectrograph of a modified type we have achieved a maximum resolution of about 60,000 towards the end of 1950¹.

Since then, we were planning to construct a larger mass spectrograph of double focusing type in order to raise the resolving power and accuracy about one order of magnitude. To obtain such a large resolving power with the ordinary mass spectrograph the following two methods may be conceivable in general: one is that of reducing the width of mass spectrum line by improving the focusing characteristic and the other that of increasing the mass dispersion of the apparatus itself by enlarging the linear dimension. In order to raise the resolving power about one order magnitude with the first method, the line width must be made $< 1 - 2 \cdot 10^{-3}$ mm with our old mass spectrograph of the modified Bainbridge-Jordan type. Moreover, with this method, there are some difficulties involved in the

measurement of line separation due to the relatively larger grain size of our self-made Schumann plate, the limited accuracy of our comparator, the error due to shrinkage of the emulsion layer at the time of development, etc. Therefore, the authors decided to adopt the second method, that is to increase the linear dimension of the apparatus itself.

Even in the second method, it is naturally important to construct the apparatus with a good focusing characteristic, and for this purpose the Mattauch type mass spectrograph is best suited one. However, the Mattauch type needs a much larger magnet than other sector types for the same mean radius of ion beam, and consequently a highly accurate technique may be required for its construction. Mainly for economic reasons, the authors were obliged to adopt a 60° sector type magnet. However, the authors found it rather difficult to set the apparatus of the modified Bainbridge-Jordan type with the linear dimension required for their purpose because of the limited floor space of the laboratory.

In order to avoid such difficulties, a new type of double focusing mass spectrograph was constructed as described in this paper.

¹ K. Ogata and H. Matsuda, Nat. Bur. Stand. Circular **522**, 59 [1953].



I. Apparatus

1. Basic consideration

The type of the newly constructed mass spectrograph is a double focusing one with a cylindrical electric field and a 60° sector type magnet of uniform field, and ion beam passes through both fields perpendicularly to the edge of the field.

For this condition, the resolving power R is expressed by the following well-known formula²:

$$R = \frac{a_e}{2s} \left(1 + \frac{l_e' - g_e}{f_e} \right),$$

where l_e' is the distance from the main slit to the edge of the electric field, g_e the distance from edge to the focus of the electric field, f_e focal length, a_e the radius of the central ion beam in the electric field, s the width of the main slit. Consequently, in order to have a large resolution, it is clearly necessary to make a_e/s large, that is a_e as large as possible and s as small as possible. However, in practice, there are certain limits for a_e and s restricted by the space and technique. Another way for increasing resolution is to increase the second term in the parenthesis of the above equation by adjusting the deflection angle of ion beam, Φ_e , in the electric field. Table I shows the relation between Φ_e and other lens' constants, f_e and g_e . To make the resolving power as large as possible, l_e'' was taken to be zero. Other quantities given in the table are calculated for the corresponding values of f_e and g_e with the condition $l_e'' = 0$. Taking into account the above mentioned conditions, the value of 3 was chosen for $1 + (l_e' - g_e)/f_e$, from which follows that Φ_e should be $\sqrt{2} \pi/3$.

Φ_e	f_e	g_e	l_e'	$1 + \frac{l_e' - g_e}{f_e}$
64°	$0.707 a_e$	0	∞	∞
80°	$0.727 a_e$	$-0.2999 a_e$	$1.471 a_e$	3.4
$84^\circ 50' \left(\frac{\sqrt{2}}{3} \pi \right)$	$0.8165 a_e$	$-0.4083 a_e$	$1.225 a_e$	3.0
90°	$0.952 a_e$	$-0.644 a_e$	$0.77 a_e$	2.8
$127^\circ 17' \left(\frac{\pi}{2} \right)$	$+\infty$	$-\infty$	0	2.0

Table I. Relation between Φ_e and lens constants.

In order to make the mass dispersion as large as possible and to enable the apparatus to fit in the laboratory, the radius a of the central ion beam in

² J. Mattauch and R. Herzog, Z. Phys. **89**, 786 [1934].

the magnetic field and the distance between the electric and the magnetic field, Δ , both were chosen to be 1200 mm. For these values of a and Δ , the radius a_e of the central ion beam in the electric field may be calculated to be 1093 mm from the following double focusing condition²

$$a_e \left(1 + \frac{f_e}{l_e' - g_e} \right) = a(1 - \cos \Phi) + l' \sin \Phi,$$

where l' is the distance from the edge of the magnetic field to the object point for the magnetic field, which coincides with Δ in this case, and Φ is the deflection angle of the ion beam in the magnetic field, and other symbols have the same meanings as before.

Under these conditions, the distance l'' between the double focus point and the edge of the magnetic field is calculated to be 4480 mm and the mass dispersion for 1% mass difference on the photographic plate about 76 mm in the vicinity of the double focus point. The magnification of image is about 1.37 and the angle between the direction of ion beam and the photographic plate about 17° . The image width may be expected to be about 4.5 times the width s of the main slit when the broadening of the line due to 2nd order aberration, scattering, etc. are neglected. When the width of the main slit is taken to be about 0.0023 mm, the maximum resolution of 700,000 may be expected.

In Table II the dimension of the main parts of the apparatus are listed in comparison with those

	New Apparatus	Bainbridge-Jordan Type
Type	Double Focusing	Double Focusing
l_e'	1340 mm	0
Electric Field	Type	Cylindrical
	Angle	$84^\circ 50'$
	Radius	1093 mm
l_e''	0	0
Δ	1200 mm	440 mm
Magnetic Field	Type	Uniform
	Angle	60°
	Radius	250 mm
l''	4480 mm	440 mm
θ	θ_s	21°
	θ_d	17°
Dispersion for 1% Mass Difference	76 mm	6 mm
Total Length	~ 10 m	~ 2 m

Table II. The dimensions of the main parts of the apparatus in comparison with the Bainbridge-Jordan type.

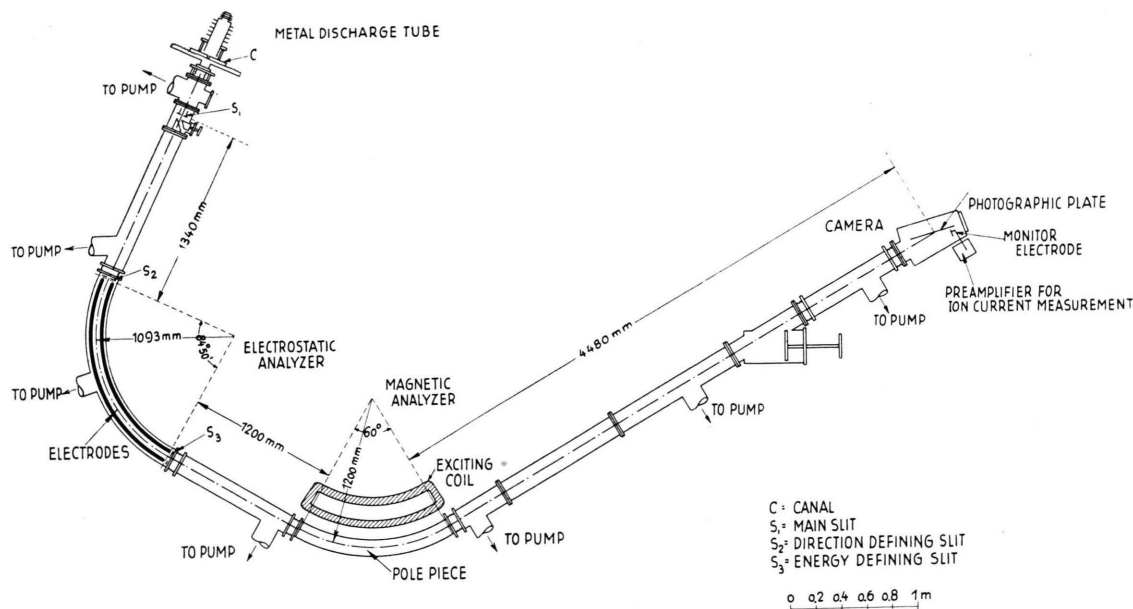

Fig. 1. The schematic diagram of the apparatus.

of the corresponding parts of the Bainbridge-Jordan type apparatus.

Based upon these basic considerations, the authors constructed a new apparatus, the schematic general view of which is shown in Fig. 1.

2. Main Parts of the Apparatus

(a) Energy Selector

The deflection angle and the radius of the central ion beam in the energy selector are $\sqrt{2}\pi/3$ and 1093 mm respectively. The circular arc electrodes of the electric field are made by aluminum casting, the radial cross section of which is $30 \times 80 \text{ mm}^2$. The space between the two electrodes is 30 mm. The outer radius of the inner electrode is 1078 mm and the inner radius of the outer electrode 1108 mm.

With the values, the relation between the potential difference X across the electrodes and the energy V of the central ion beam may be estimated as follows

$$V = 18.21 \cdot X.$$

The case of the energy selector consists of four iron parts; two curved side plates and an upper and a lower plate, fastened together with rubber gaskets by bolts, thus making it air tight. The two ends of the case are joined to the connecting tubes of the apparatus. The two electrodes are bolted with quartz insulator to the base of the case. The cross section of the energy selector is shown in Fig. 2.

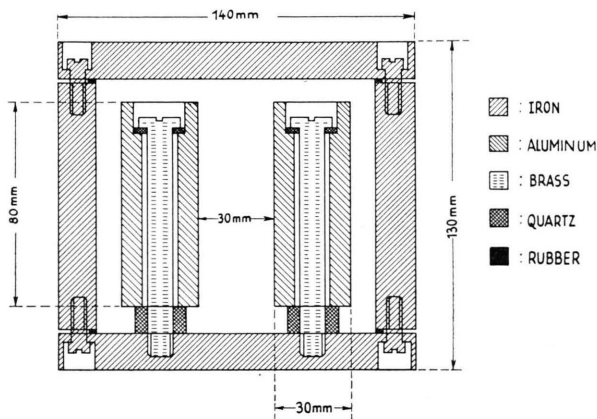

Fig. 2. Radial cross section of the energy selector.

The slit which defines the diverging angle of the ion beam is located near the edge of the electrodes at the entrance of the selector. The width of the slit can be adjusted from 0 to 3 mm from outside the selector chamber. The width of the energy defining slit near the other edge of the electrodes at the exit is also externally adjustable.

(b) Magnet

The magnet is a 60° sector type with a 1200 mm radius of the central ion beam. The radial cross section of the magnet is shown in Fig. 3. The magnet is made of pure iron with a carbon content of 0.08%.

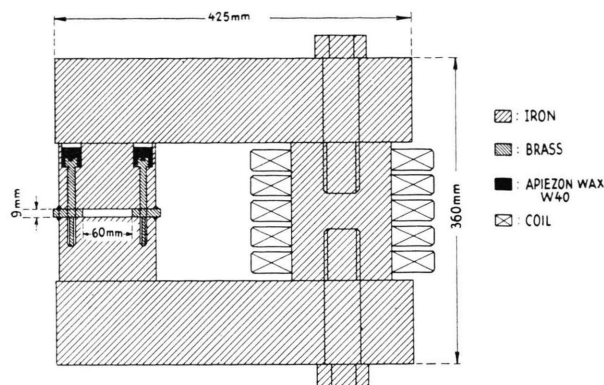

Fig. 3. Radial cross section of the magnet.

The exciting coil consists of 3,500 turns with a total resistance of 123Ω .

The pole gap is 9 mm. In the original design this gap was 5 mm, but later changed to 9 mm for reasons to be explained later on in this paper. The pole pieces are spaced by means of brass pieces. The surfaces of the two pole pieces are smoothed and flattened to the degree of 0.01 mm and are placed parallel to each other with the same degree of accuracy.

The space surrounded by the two pole surfaces and brass pieces makes a vacuum chamber. The vacuum seal is made with Apiezon Wax 40.

(c) Ion Source

A metal cylinder of the ordinary gas discharge type is used for the ion source. The anode cylinder made from an aluminum rod has an inner diameter of about 70 mm and a length of about 200 mm. The cylinder is surrounded by some air cooling fins. The cathode and the guard ring made of aluminum are screwed to the cathode holder. The plane of the flat cathode and the flat end of the guard ring are placed in the same plane.

At the center of the cathode is a canal of 0.8 mm diameter. The anode cylinder and the cathode holder are held together with the aid of the insulating porcelain disc. The whole assembly of the ion source is connected to the main slit chamber by means of a device which can change the position and direction of the ion beam by adjusting.

(d) Main slit system

The main slit system which is located at about 40 cm from the canal consists of a vertical main slit with a horizontal auxiliary slit. The vertical main

slit is made of two stainless steel blades of about 0.7 mm thickness which are fixed on the main holder with a gap of about 0.05 mm. By rotating the main slit holder around the vertical axis at the center of the slit from outside the vacuum chamber, the effective width of the slit for the incident beam can be made adjustable. This rotation method of adjusting the effective width of the slit is similar to the principle used by Ewald³.

In front of this main slit there is another auxiliary horizontal slit with a fixed width of about 0.2 mm to define the beam height. The vertical main slit is made to shift vertically with the rotation of the slit holder, so that the fresh part of the blades could be exposed to the incident beam. The main slit can also be shifted side way horizontally for a fine adjustment of the position of the slit from outside the vacuum chamber.

A shutter for the ion beam is inserted between the canal and the main slit system. The source and the slit chamber can be isolated from other parts of the apparatus by a vacuum lock valve.

(e) Camera

The camera chamber contains a cassette for the photographic plate and its holder. The cassette holder can be shifted vertically by rack and pinion for taking three or four series of mass spectra. The cassette is made to change its position in the cassette holder, so that the photographic plate can be set on the focal plane. The size of the photographic plate used is $45 \times 300 \text{ mm}^2$.

Near the end of the heavy mass side of the photographic plate is an ion collecting electrode with a slit of about 0.2 mm width, which is used for detecting the ion current to enable the estimation of the suitable exciting current of the magnetic field and at the same time to adjust the relative intensity of the desired doublet.

(f) Evacuating System

Seven sets of the evacuating pumps are connected to the apparatus at the positions indicated in Fig. 1. Each set consists of a 7" oil diffusion pump of fractionating type and a 4" oil diffusion booster pump backed by 60 l/min oil rotary pump. "Apiezon oil C" is used for 7" pump.

The source, the energy selector, the magnet and the camera chamber are connected by 6" Φ iron

³ H. Ewald, Z. Naturforschg. 5a, 229 [1950].

pieces. The vacuum limit attained by continuous evacuation of a few days may be estimated to be about $1 - 2 \times 10^{-6}$ mm Hg with Fogel type ionization gauge.

II. Assembling and Adjustment of the Apparatus

The construction of the main parts of the apparatus were completed in the autumn of 1952. At first, the magnet was set on a concrete block and was adjusted that its median plane lies in the horizontal plane. Then the energy selector was set at the calculated position relative to the magnet without connecting tubes and adjusted that the median plane of the energy selector lies in the same plane as the median plane of the magnet. The main slit was then set at the calculated position relative to the energy selector.

After connecting the main slit chamber and the energy selector with the connecting pipe, the ion source was set in operation and by examining the beam intensity detected on the fluorescent screen at the entrance slit of the energy selector, the relative position of the canal was adjusted.

Having confirmed the ion beam with the fluorescent screen at the exit slit of the energy selector, the connecting tube was extended to the magnet and the relative position of the source and the selector was slightly adjusted that the ion beam should come in the center of the gap at the entrance of the magnet. The ion beam was easily confirmed at the exit of the magnet with the fluorescent screen without any further adjustment.

Finally the camera chamber previously set at the calculated position and the magnet were connected by the connecting tubes. The primary setting and assembling of the whole apparatus was completed by March 18, 1953.

On April 9th, 1953, the first test was successfully carried out with $N_2^{14} - C^{12}O^{16}$ doublet. At this time the line breadth was about 4 mm, but the dispersion was close to the calculated value.

After the experimental investigation of the focal position had been carried on for about two months, it was found that the spectral lines at different positions on the photographic plate were not exactly parallel to each other and that the pole surface of the magnet was not sufficiently flat.

The above findings may be considered to be due to the existence of non-uniformity of the magnetic field strength in radial direction. Therefore, the surface of the magnet pole was repolished and the pole gap increased from 5 mm to 9 mm, this work being finished by the end of 1953.

The fine adjustment of the focusing position was started again and the maximum resolving power of about 330,000 was obtained before the summer of 1954. However, it was found that the focusing position for different magnetic field strength had shifted to a considerable extent and also that the focusing position and the line shape were critically affected by the entrance position and the angle of the incident ion beam to the magnet. These facts may be inferred to have resulted from the change of the strength and the shape of the stray magnetic field.

So the magnetic shield channels made of pure iron were introduced near both ends of the magnet. The inner dimensions of the channels were $42 \times 10 \times 170$ mm³ and the thickness of the iron wall of the channel about 16 mm, and the clearance between the edge of the shielding channel and the pole edge was 12 mm. After this development, accurate determining work of the focussing position had been carried on since the autumn of 1954. In the middle of December, 1954, a resolution of about 500,000 was obtained at the best condition. The dispersion for 1% mass difference was about 9 cm. At that time, the lengths of l'_e , Δ and l'' were about 132 cm, 124 cm and 490 cm respectively. The discrepancies between the real and calculated values of these quantities may be due mostly to the discrepancy between the effective and calculated radius of the central ion beam in the magnetic field and to a

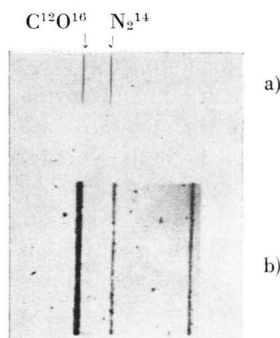

Fig. 4. $N_2^{14} - C^{12}O^{16}$ doublet, a) taken with the present apparatus ($\times 1$); b) taken with the modified Bainbridge-Jordan type apparatus ($\times 20$).

small deviation of Φ from 60° and also probably to the small ϵ' . This fact may result from the fringing field effects of the magnetic and electric fields.

The photograph of the $N_2^{14} - C^{12}O^{16}$ doublet is shown in Fig. 4, and for comparison the photograph of the same doublet taken by the modified Bainbridge-Jordan type apparatus is also shown. The former is a contact print (natural size) and the latter is enlarged by about twenty times.

III. Method of Mass Calibration

The dispersion obtained by the apparatus is about fifteen times larger than that by the modified Bainbridge-Jordan type. So it is impossible to use the similar method for mass calibration as with the Bainbridge-Jordan type apparatus⁴.

The following method is now adopted for mass calibration; that is, when members of the line series are photographed successively by changing the potential difference between the energy selector electrodes while keeping the magnetic field strength constant and when the corresponding fractional potential differences could be accurately measured to the fifth or sixth significant figure, the line series so obtained may be used as mass calibration line series.

Of course, during the whole exposure time of each line series, the strength of both fields, electric and magnetic, must be kept exactly constant with a fluctuation of less than 10^{-6} . Such constancy of the fields is also necessary for having a very high resolution. In order to achieve such field constancy, the stabilization of the potential of the electric field and of the exciting current of the magnet is a very serious problem.

For the potential supply to the energy selector electrodes, about 1,360 volts, the layer dry batteries are used and these batteries are separated into two groups, positive and negative to the ground, and each group is stored in a Dewar's vessel. The Dewar's vessels and the standard cells, which are used for the additional potential supply in order to shift the line for taking the mass calibration series, are stored in a wooden heat insulating box. The temperature inside the Dewar's vessels is measured by Beckmann thermometer to an accuracy of about $0.002^\circ C$.

During the whole exposure time the temperature in the Dewar's vessels is kept constant with a change of less than $0.005^\circ C$, which corresponds to the voltage change of the dry batteries less than 10^{-6} .

For the magnetic field excitation, the storage batteries of 140 amp. hr. capacity are used, and the exciting current is about 230 mA for photographing the $N_2^{14} - C^{12}O^{16}$ doublet having the above mentioned energy.

For the field instability, the following two causes are supposed: one is the natural drift due to the monotonous decreasing of the electromotive force of the battery and the other is fluctuation by miscellaneous factors: temperature change, electric disturbances, irregular change of battery's electromotive force, etc. . . For the stabilization of the magnetic field strength, the exciting current stabilizing method is adopted.

The method consists of two stages; the first stage is the prevention of the monotonous decreasing of the exciting current by decreasing the plate current of the vacuum tube inserted parallel to the magnet coil, which is carried on by changing continuously the grid potential, and the second stage is the prevention of the magnet current fluctuation.

In the second stage of the method, the stabilizing principle similar to that used by *Mattauch* and his coworkers⁵ is adopted. The voltage change across the standard resistance inserted in series to the earth side of the magnet coil due to the current fluctuation is measured by galvanometer with reference to the cadmium standard cell which is kept in the Dewar's vessel. The standard resistance is kept in oil in the heat insulating box with a temperature fluctuation of less than $0.1^\circ C$. With this temperature fluctuation the change in resistance may be considered to be less than 10^{-6} .

The light reflected by the mirror of galvanometer is focussed on one edge of a prism, where it is reflected again into two opposite directions and enters two photocells on either side of the prism. Any change in current through the magnetic coil may result in an unbalance of the light intensities entering the two photocells connected in series. The potential change at the fixed point between the two photocells caused by this unbalance is used to re-

* The details of the focusing characteristics of the apparatus will appear elsewhere by one of the authors.

⁴ K. Ogata and H. Matsuda, *Phys. Rev.* **89**, 27 [1953].

⁵ Through private communication with Prof. J. *Mattauch* and Dr. E. *Everling*.

gulate the magnet current by changing the plate current of another vacuum tube inserted in parallel to the magnet coil.

With this second stage of magnet current stabilization, the compensation of the monotonous decreasing of the exciting current may be achieved to some degree. However, in this case, it has been difficult to compensate the whole natural drift within the required time. Because of the above mentioned stabilizing mechanism, the stability of the magnet exciting current is about one ppm or slightly better, but occasionally an unexpected shock appears in the magnet current due to a high tension surge. The circuit for this stabilizing device is shown in Fig. 5.

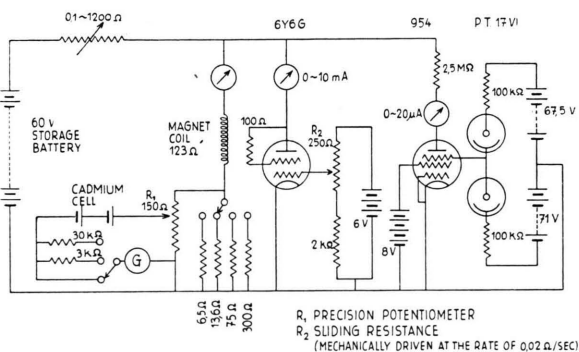

Fig. 5. The stabilizing circuit of the magnet exciting current.

In order to test the reliability of the above mentioned mass calibration method, seven to nine $N_2^{14}-C^{12}O^{16}$ doublets are photographed as mass calibration series by the following procedure. The basic potential of the energy selector electrodes is supplied by the dry batteries, called base batteries, the middle point of which is kept at ground potential, and at first one exposure is made with this potential. The succeeding six to eighth exposures are made by successive addition of standard cells on both positive and negative sides of the base batteries. In Fig. 6, such mass calibration series are shown.

After these exposures, the total voltage of the base batteries is measured potentiometrically by the following principle: That is, a steady current of about 1 mA flows through the standard resistances from the other dry battery set, the total voltage of

which is slightly higher than that of the base batteries, and the current can be accurately adjusted by the variable resistance so that the voltage appearing across two ends of the standard resistance is exactly balanced with the total voltage of the base batteries. If the current through the base batteries is kept below $1 \mu A$ during adjustment, the voltage change of the base batteries may be considered below 10^{-5} .

When this balancing is achieved, the divided potential across a certain point of the standard resistances is measured by precision potentiometer, and the ratio of the resistances of this part of the standard resistance to the total resistance is estimated by means of a precision Wheatstone bridge. From the above measured values, the total voltage of the base batteries may be calculated.

The voltages of the additional standard cells are determined by comparing them to the voltage of one standard cell which is arbitrarily selected as a reference standard. This standard cell used as a reference is also used in determining the total voltage of the base batteries. The fractional potential differences as estimated from the above measurements are used in drawing the mass calibration curve as an equivalent of the fractional mass differences in ordinary mass calibration.

Fig. 7 shows the voltage measuring circuit of the base batteries and Fig. 8 one example of the mass calibration curve so obtained. The scattering of the measured points may result from an insufficient stability of the magnetic field strength during the

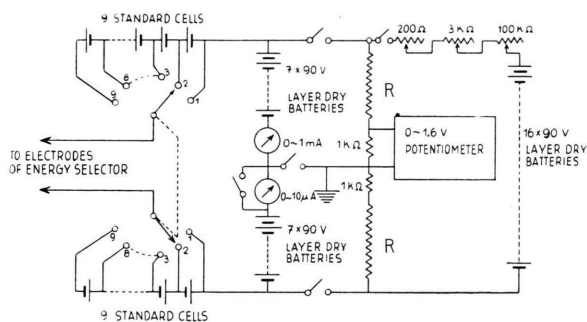

Fig. 7. Measuring circuit of the potential difference between the energy selector electrodes. $R = 5 \times 100 \text{ k}\Omega$ standard resistances.

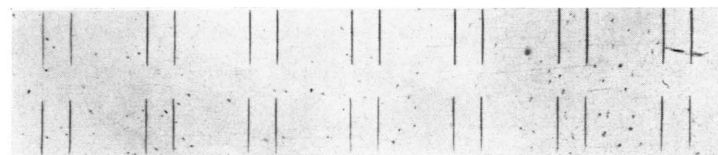

Fig. 6. Mass calibration series: $N_2^{14}-C^{12}O^{16}$ doublets are shifted by changing the potential difference between the energy selector electrodes. The base potential is 1350.40 volts and each shift is made by successive addition of 2.03670 volts.

exposure of the whole numbers of the calibration series.

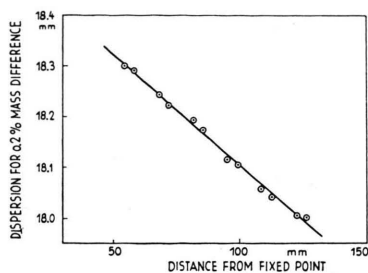

Fig. 8. Dispersion curve for 0.2% mass difference.

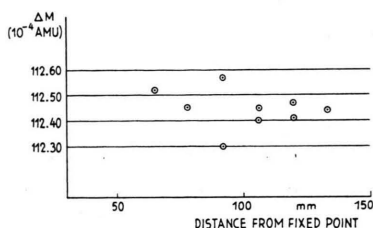

Fig. 9. Mass differences of $N_2^{14}-C^{12}O^{16}$ doublet on the various positions of photographic plate.

The mass difference of $N_2^{14}-C^{12}O^{16}$ doublet is determined preliminarily by the above mentioned calibration method. Fig. 9 shows the reliability of the measurement under the present condition of the new apparatus. The simple arithmetical mean of

$N_2^{14}-C^{12}O^{16}$ doublet mass difference so obtained is 112.441 ± 0.019 (10^{-4} amu), where the error quoted indicates the probable error.

IV. Conclusion

The dispersion of the newly constructed large mass spectrograph is satisfactory but the exact double focusing point has not yet been found. Sometimes the focus planes, directional and velocity, are observed to shift slightly due to unexpected causes. The investigation of the cause is now being carried on.

The calibration method used here may be checked by comparing it with the ordinary calibration method, for example, using hydrocarbon fragments in high mass range, say mass 200 or 300.

The authors wish to express their thanks to Prof. J. Mattauach and Dr. E. Everling for their kind information on the magnetic exciting current stabilizer, to Dr. R. Herzog for his kind information on the magnetic stray field shielding, to Prof. J. Mattauach and Prof. S. Kikuchi for their encouragement, to Profs. K. Hushimi, T. Nagamiya and other members of the Faculty for their financial support, to Prof. T. Asada for his continuous interest in their mass determination work, to Mr. S. Matsumoto and Mr. T. Nakatsuka for their kind assistances, and to Dr. and Mrs. Nishiwaki for their very kind suggestion on the languages.

The ion source of the Amsterdam Isotope Separator

J. KISTEMAKER, P. K. ROL, J. SCHUTTEN and C. de VRIES

Laboratorium voor Massaspectrografie, Stichting F.O.M., Hoogte Kadijk 202, Amsterdam. C.
(Z. Naturforschg. **10 a**, 850—856 [1955]; eingegangen am 26. Juli 1955)

To J. Mattauach for his 60th birthday

The ion source has as essential parts:

1. the discharge chamber with filament,
2. the furnace for the production of the gas (vapour),
3. the heated screens and the labyrinths,
4. the acceleration- and lens electrode,
5. the power supplies and cooling systems,
6. the arc stabilization.

These parts are shown and explained. Especially a survey has been given of the five types of breakdown which can disturb a smooth ion production.

§ 1. The discharge chamber with filament

The ion source required for the separator is an arc source^{1, 2, 3}. Electrons originating from the filament are accelerated through one or two hundred

volts and ionize the gas molecules with which they collide. For the following explanation see fig 1.

We had to construct the source block (1) from a material that should resist chemical reaction with various substances, even at high temperatures. There-

¹ C. J. Zilverschoon, An Electromagnetic Isotope Separator, Thesis University Amsterdam, 1954.

² L. O. Love and W. A. Bell, U.S.A.E.C., A.E.C.D. 3502, 1950.

³ R. H. V. M. Dawton and M. L. Smit, Quarterly Rev. **IX**, 1 [1955].